



**AMERICAN EAGLE**<sup>®</sup>  
**FOOD MACHINERY, INC.**

## **AE-1220** **40 Quart Fixed Bowl** **Spiral Mixer**

773.376.0800 (P) • 773.376.2010 (F) • 3131 S. Canal St. Chicago, IL 60616

### ***Spiral Mixing Technology: The secret to better dough!***

American Eagle<sup>®</sup> spiral mixers imitate hand kneading and rolling motions. The gentle coordinated movement of bowl and agitator keeps dough cool while mixing for consistent texture. Dough blends in half the time as a comparable planetary mixer!

### ***Quality Design***

- Dual motor system, 1.5 HP Agitator, 0.5 HP Bowl
- Heavy-duty, single mold cast iron construction
- Heavy-duty multiple V-belt drive transmission
- Reversible mixing bowl with fixed design, handles 44lbs dough
- Superior electronic components and wiring ensure reliable operation
- Motor start-up relay system reduces stress on belts
- NSF approved heat treated enamel coating resists scratches, dents, and rust
- ETL certified to conform to: NSF No. 8, CSA, CE standards



### ***Standard Features***

- Convenient forward/reverse/stop switch for bowl
- 2 fixed agitator speeds with convenient control switch
- Thermal overload protection
- Safety guard with auto-shutoff
- Front guard opening for adding ingredients while mixing
- Heavy Duty, 7 foot, four wire power cable\*
- Warranty: 1 year parts / 90 days labor\*

\*Warranty must be registered. Improper wiring to plug and electrical service will void warranty, improper installation voids warranty, refer to operation manual for details. Extended Warranty available at extra cost.

\*\* Special Order Item

### ***Other Available Sizes:***

- AE-3050 80 Quart, 110 lbs dough, 66lbs flour
- AE-4065 100 Quart, 154 lbs dough, 99 lbs flour
- AE-5080 120 Quart, 176 lbs dough, 110 lbs flour
- AE-75K 190 Quart, 264 lbs dough, 145 lbs flour
- AE-100K\*\* 220 Quart, 330 lbs dough, 220 lbs flour
- AE-125K\*\* 250 Quart, 396 lbs Dough, 275 lbs flour

Proud Member of:  
  
North American Association of  
Food Equipment Manufacturers

**Quality • Value • Reliability**



**AMERICAN EAGLE**<sup>®</sup>  
**FOOD MACHINERY, INC.**

**AE-1220**  
**40 Quart Fixed Bowl**  
**Spiral Mixer**

sales@ameagle.biz • www.americaneaglemachine.com

*Lower your total cost of ownership with American Eagle<sup>®</sup> spiral mixers! Quality design, competitive pricing, and reliable support make us the value leader in the industry.*

**Specifications**

Model	Capacity***	Motor	Voltage V/HZ/PH	Amps	Transmission	Agitator Speeds (RPMs)	Safety Guard	Timer
AE-1220	40 Quarts Max 26 lbs. of flour Max 44 lbs of dough	1.5 HP Agitator 0.5 HP Bowl	220 / 60 / 3	7 / 4	Belt Driven	1st: 142 2nd: 284	Yes	No

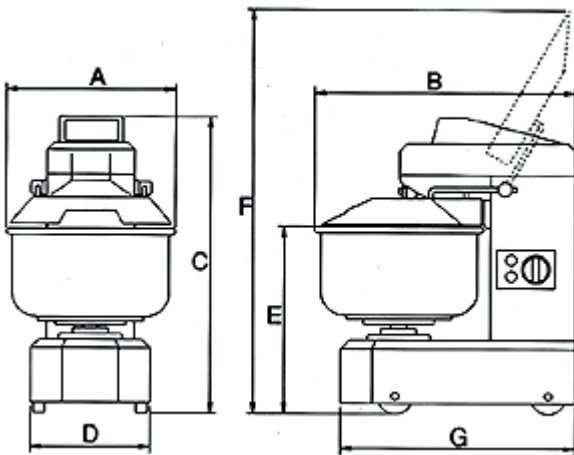

**Measurements**

Dimension	Inches	Centimeters
A	20	50.8
B	33	83.9
C	38	96.5
D	15	38.1
E	25.5	64.77
F	48.5	123.2
G	29.8	75.7

**Dimensions and Shipping Information**

Model	Overall Dimensions (w/Guard Raised)	Foot Print	Net Weight	Shipping Dimensions****	Ship Weight	Freight Class
AE-1220	20"W x 33"L x 38" (48.5") H	15"W x 32.8"D	331 lbs. (150 kg)	25.2"W x 40.2"L x 48.5"H	450 lbs. (204 kg)	85

\*\*\*Capacity will be diminished depending on dough density, rated capacities are for typical bread dough. Overloading will void warranty

\*\*\*\*Crates are affixed to a skid (pallet). The weight and dimensions of this skid are included above and may vary from shipment to shipment.



**Quality • Value • Reliability**