

## **Bun Autoloader Line Model AL17**

- Lane, group, slice, stack and bag
- 60 bags per minute
- Improved hinge slicers design
- New generation engineered spindle bearing system
- Precision parallelogram height adjustable pressure table mechanism
- Improved blade belt double takes up tensioning for no slippage
- Rotary bag table with 100% CNC components
- Kinetic servo drive with high ratio planetary gear reducer
- Single motor, distributed, drive train for reliability, consistency and ease of maintenance

**Refurbished bun bagger gets a test drive.**

[CLICK HERE](#)

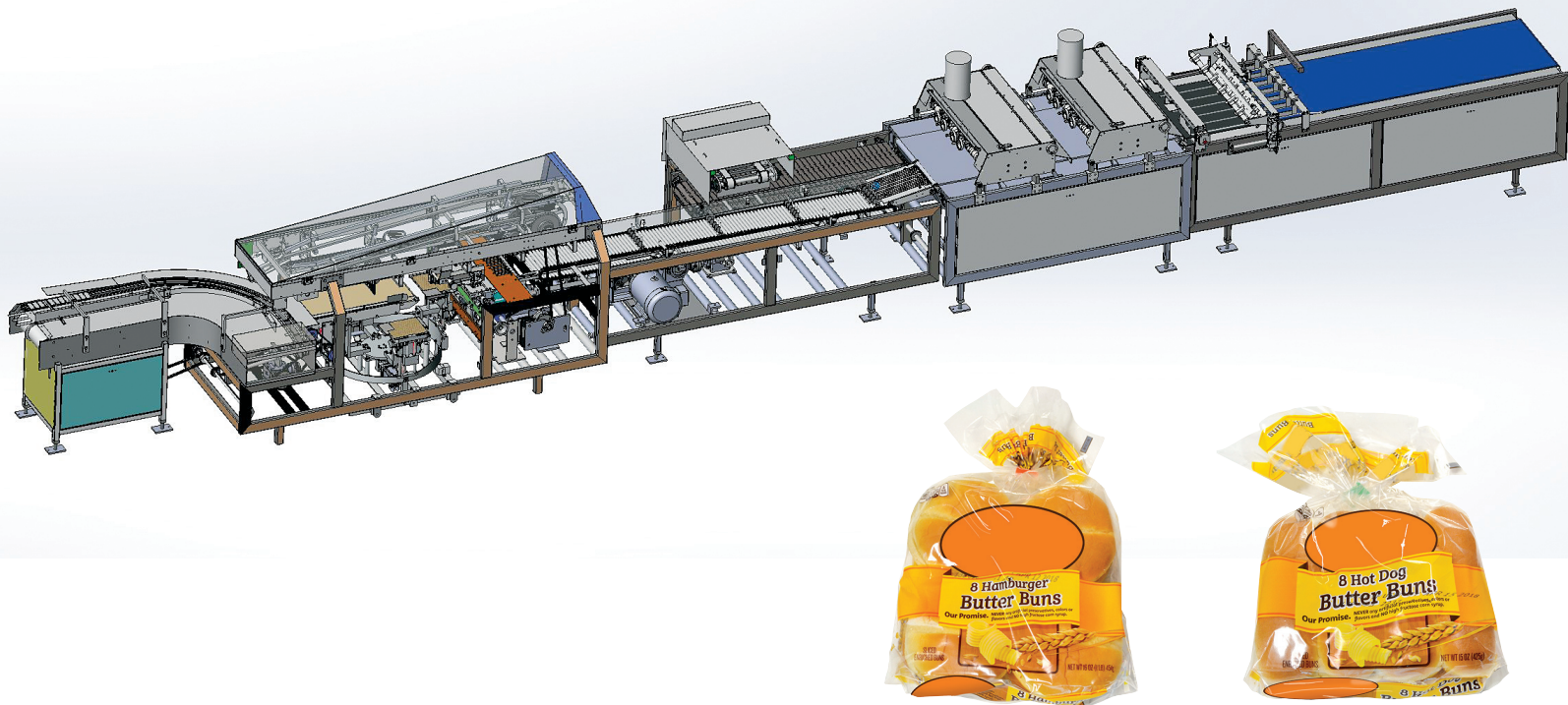

**1 (913) 378-3800 • [www.lenexamc.com](http://www.lenexamc.com)**

*Experience, service, respect. We have the best recipe for your success.*

**Bun Autoloader Line Model AL17**

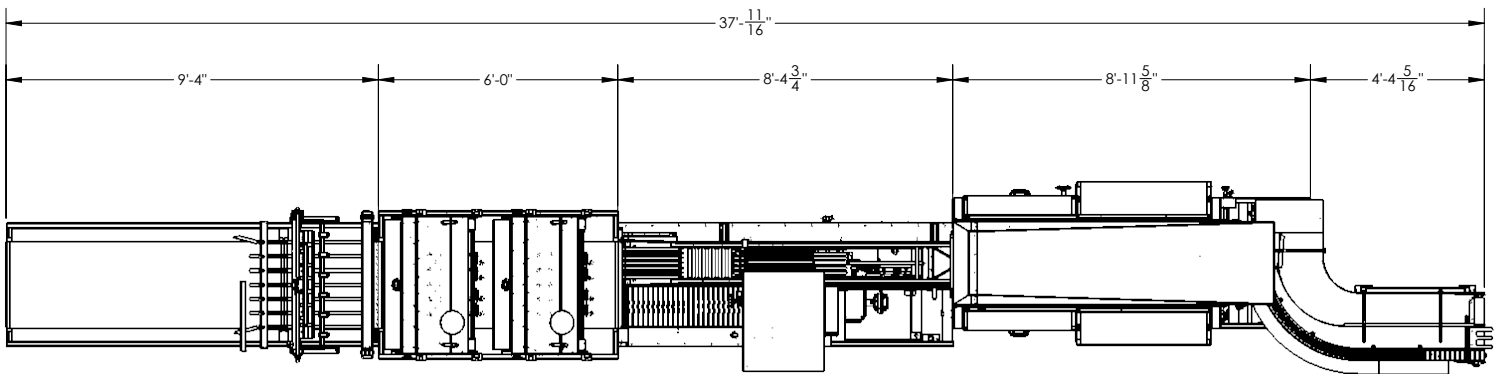

*Refurbished bun bagger gets a test drive.*

[CLICK HERE](#)

**1 (913) 378-3800 • [www.lenexamc.com](http://www.lenexamc.com)**

*Experience, service, respect. We have the best recipe for your success.*