

Call Toll Free 1-888-411-2131

Mini-Vert

Vertical Airbagger

FAST & SIMPLE BAGGING

- ✓ Three times faster than manual bagging
- ✓ Works vertically like a common bread chute
- ✓ Slices don't shift during loading
- ✓ Bag hard / soft crusted, sliced / unsliced breads
- ✓ Next bag pops up automatically
- ✓ Mounts directly to your slicer or bench
- ✓ Up to 1,200 packages/hour



**CUT YOUR
BAGGING
COSTS IN HALF!**



**Qualifies for IRS
Section 179 Tax
Savings**



Load



Feed



Release



Twist



Closure

Five steps to bag sliced bread

Cut your bagging costs in half and finish three times faster than manual bagging!

Bagging sliced bread is a thankless job. The last step of the bread making process is always rushed by the delays in baking and cooling, staff pulled away to serve customers and trucks waiting for bread to be loaded.

Mini-Vert Airbagger is the perfect slicer companion and mounts easily to your slicer. The vertical design prevents bread slices from shifting and the patented wings eliminate bag tearing. The next bag inflates instantly and holds it ready for your next loading.

You may mount the bagger to most bread slicers using the optional adjustable mounting bracket. This allows you to position the bagger conveniently for the operator and swing it away when cleaning or servicing the slicer. Table brackets are also available.

You can bag up to 1,200 products per hour but the slicer becomes the slowest point. Most gravity feed slicers can slice about 400 to 500 loaves per hour. Our customers tell us that their staff manually bagging can only bag 100 to 150 loaves per hour and see immediate improvements to the full slicer capacity. Depending on the volume of bread that you do, our baggers can pay for themselves in a few weeks to a few months. **No bakery is complete without one!**



**Save up to 3½ cents
on every loaf!**

TESTIMONIAL

In 18 years of owning a bakery, I have never come across a piece of equipment that paid for itself so quickly. It was like raising the prices on all our bread products without listening to customer's complaints.

L. L. Audrey's Family Bakery

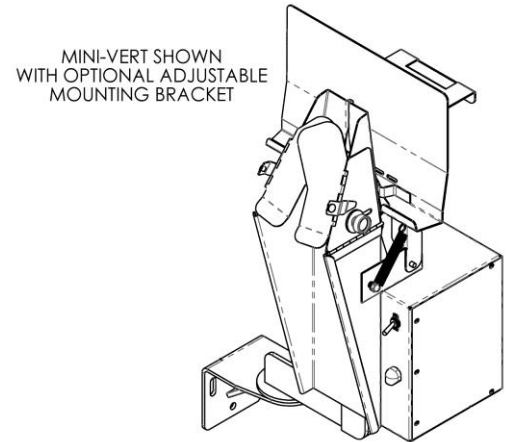

MINI-VERT SHOWN WITH OPTIONAL ADJUSTABLE MOUNTING BRACKET

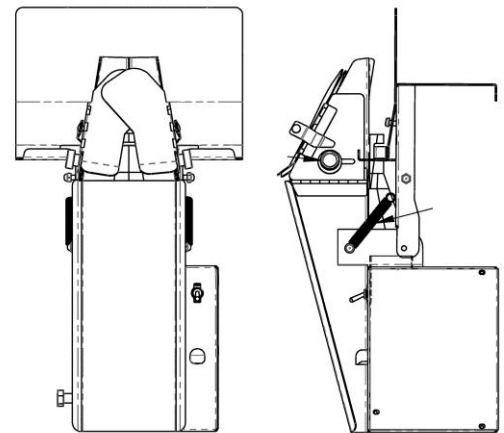

BLOEMHOF Mini-Vert Bagger Specifications

- MODEL:** **M** 5" Wide chute, 9" minimum bag width
- M7** 7" Wide chute, 10 1/2" minimum bag width
- Bags:** Wicketed polyethylene and polypropylene bakery bags, 5" to 16" wide and up to 32" long when measured flat
- Mounting:** Adjustable mounting bracket
 Table mounting bracket
- Motor:** 90 cfm air blower 1.0 Amps 1 Ph / 115V / 60Hz
- Shipping Weight:** Approximately 34 lbs.
 Specifications subject to change without notice



Sold By:

Manufactured by:
Bloemhof Inc. 74 MacDonald St.
Kirkland, Quebec, Canada H9J 3Z7
1-514-505-3922 info@bloemhof.com