

**SECTION DETAIL**  
Scale: N.T.S.

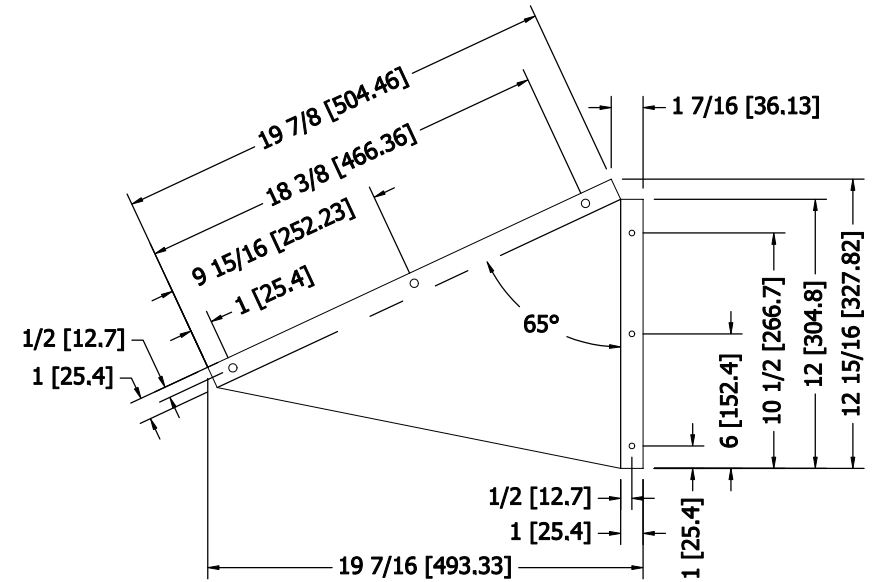
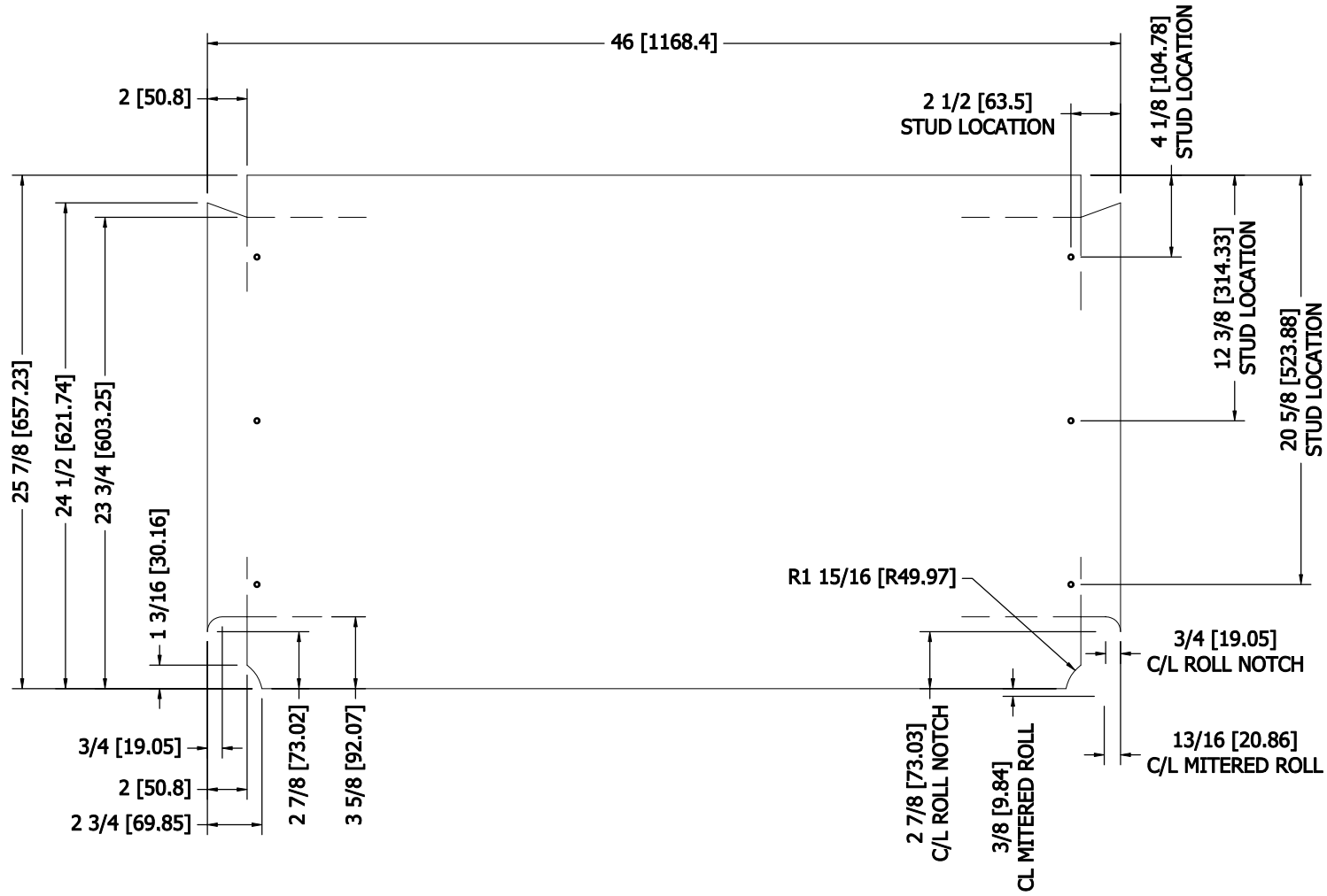

SLANT RACK BRACKET - RIGHT SIDE SHOWN  
 LEFT SIDE TO BE A MIRROR IMAGE  
 1 EA. RIGHT AND 1 EA. LEFT REQUIRED